

# **Silent Storm DMX Snow Machine**

## Operator's Manual

# Table of Contents

<b>Introduction</b> .....	<b>3</b>
<b>Warning</b> .....	<b>3</b>
Important Safety Instructions: .....	3
<b>Technical Specifications</b> .....	<b>4</b>
Technical Drawings .....	4
<b>Operating Procedure</b> .....	<b>5</b>
<b>Maintenance</b> .....	<b>5</b>
Exterior.....	5
<b>Recommended Fluids</b> .....	<b>5</b>
<b>Warranty</b> .....	<b>6</b>
<b>Contact Information</b> .....	<b>6</b>

**Note: Please read entire manual before operating the Silent Storm**

# Introduction

The Silent Storm is a snow machine, which can produce spectacular visual effects by creating an artificial snow flurry for distances of up to 40ft. The machine comes with a remote control and is DMX compatible. It is designed for applications requiring quite operation.

It can be seated, or mounted on an optional truss mount bracket. Adjustable distance and volume of snow can be used to achieve different visual effects.

With proper usage and regular maintenance the Silent Storm will provide years of snow making effects.



## Warning

### Important Safety Instructions:

1. Keep this device dry to prevent danger of electric shock.
2. Use in 3-prong grounded electrical outlets only.
3. Always unplug the machine when you are handling any fluids around this machine.
4. Turn off power when not in use.
5. For adult use only. Snow machine must be installed out of the reach of children.
6. Never leave the unit running unattended.
7. Do not aim out put nozzle directly at anyone.
8. Locate the snow machine in a well-ventilated area.
9. Never cover the unit's vents – to ensure adequate ventilation allow a free air space of at least 1" around the unit.
10. Never add flammable liquids (oils, gasses, or scent) to the snow fluid.
11. Use only Ultratec Special Effects Snow Fluid.
12. Always make sure there is sufficient fluid in the bottle (4L / 20L Fluid Container) to prevent damage to the pump.

**MSDS available at [www.ultratecfx.com](http://www.ultratecfx.com)**

# Technical Specifications

<b>Model:</b>	Silent Storm
<b>Part Number:</b>	CLS 7100 Silent Storm - 120 Volt CLS 7105 Silent Storm - 120 Volt - w/ Industrial Option CLS 7150 Silent Storm - 220-240 Volt CLS 7155 Silent Storm - 220-240 Volt – w/Industrial Option
<b>Length:</b>	23in 58.5cm
<b>Width:</b>	10.125in 25.7cm
<b>Height:</b>	10.1in 26.8cm
<b>Net Weight:</b>	22lbs 10kg
<b>Net Weight w/ fluid:</b>	32lbs 14.5kg
<b>Power Rating:</b>	120 Volt A.C. 50/60 Hz. 10 Amps. 220-240 Volt A.C. 50/60 Hz. 5 Amps
<b>Fluid:</b>	Ultratec Special Effects Snow Fluid

## Technical Drawings

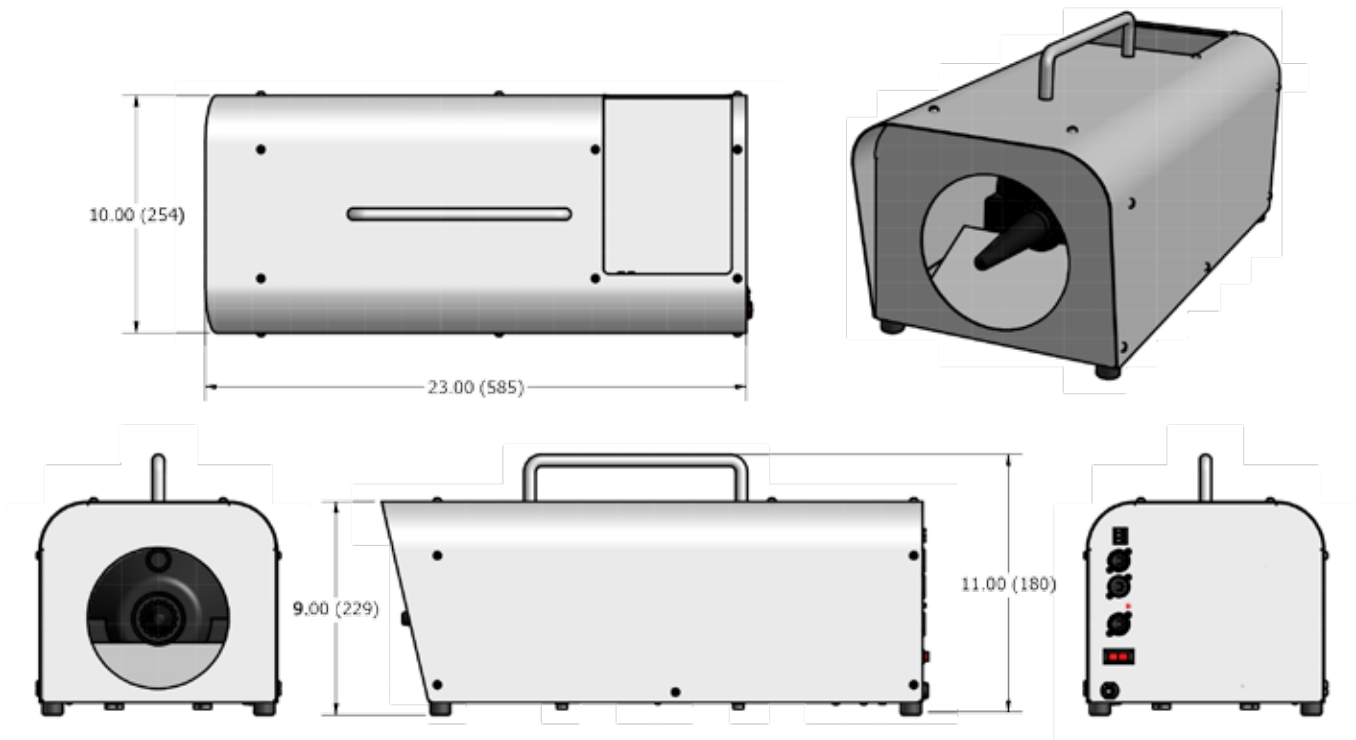

# Operating Procedure

The Silent Storm snow machine requires 120 volts AC at 10 amps (CLS 7100) or 220-240 Volts AC at 5 amps (CLS 7150). The unit can be operated from a wired hand held remote or from a DMX control signal. When DMX data is present the hand held remote is ignored. A valid DMX signal causes the LED to light on the rear of the machine.

The blower starts before the pump, to allow it to come up to speed. When shut off, the blower runs for several seconds to purge the system. The pump rate is dependent on the blower settings. Low blower settings restrict pump range.

The remote has an On/Off switch with power LED and two flow control knobs. It plugs into the rear of the machine. The remote may be extended with a 100' cable. The first knob has a cloud illustration and controls the air speed. Fluid output is controlled by the second knob, which is denoted with a snowflake. As the air speed is reduced the maximum fluid rate is also reduced to prevent excess foam from forming on the nozzle. A range of flake size, noise levels and distances can be achieved by adjusting the two controls.

If the DMX control is used the remote does not need to be installed. DMX control data can also vary the blower and fluid flow. Set the base DMX address on the rear of the machine. The base DMX address controls the air speed but the base address +1 controls the fluid output rate. Don't set the base DMX address above 511.

## Maintenance

The fluid pump is subject to burn out if run dry for any period of time. Take care when priming the pump when changing jugs. Keep the air intake ports on the bottom of the chassis free from blockage. With time the sock may accumulate residue, which will impede performance. Running clear water through the machine and rinsing off the sock will restore performance. After each event flush the unit with 2L of clear water. Protect the unit from freezing. In extreme cold, performance will be reduced.

Do not allow the snow liquid to become contaminated. Always replace the caps on the snow liquid container and the snow machine liquid tank immediately after filling. Before storing, flush out system with clean water.

If you experience low output, mechanical noise or no output at all, unplug immediately. Check fluid level, the external fuse, remote connection and power from the wall. If all of the above appear to be okay, plug the unit in again. If snow does not come out after 30 seconds, check the hose attached to the tank to make sure there is fluid going through the hose.

## Exterior

To clean, wash with mild soap and warm water.

## Recommended Fluids

**True North Snow Fluid:** The secret to creating realistic-looking snow is in the fluid. Extensive research went into creating the best possible snow fluid that is odorless and environmentally safe.

**Ultimate Extra Dry Snow Fluid:** Retaining the same snow properties as our popular True North Snow Fluid, this extra dry solution is perfect for a densely moist and humid environment.

**Concentrated Snow Fluid:** Available in a 410ml bottle, this Snow Fluid Concentrate is ideal for cost effective transportation and minimizing storage space without compromising quality.

**True North Extreme:** The True North Extreme Snow Fluid evaporates very quickly. This snow fluid is recommended for well ventilated environments and great for outdoor venues.

# Warranty

<b>Warranty:</b>	Hardware products come with a one year warranty on parts and labor. Unless stated otherwise, this will refer to manufacturer defects only. All warranty is based on destination of the original sale. Any additional costs incurred are the responsibility of the Dealer and/ or the customer. Abuse or poor maintenance is not accepted. Proof of purchase or proof of sale must always accompany all warranty returns. An RA (Return Authorization) number must be noted on the outside of each box being returned to our facility. Any package(s) without an RA number clearly marked, will not be accepted by our receiving department. Freight on warranty items are freight prepaid to our facility and we will prepay freight back to your facility following repair. This will be done by the most economical means available. Should you require the item express-returned, the dealer is responsible for request indication and any difference in freight cost.  Export Distributors are required to carry out the warranty repair, parts will be supplied by Ultratec.
<b>Return Policy:</b>	Return of any product must be done within 30 days of purchase. The package must be returned freight prepaid and the RA number clearly marked on the outside of the box.
<b>Warning:</b>	Ultratec Special Effects considers all of it's product to be safe for use in the application it was intended. Ultratec Special Effects takes no responsibility for misuse or incorrect use. Always refer to the Product Manual for proper use.

---

## Contact Information

### Head Office

Ultratec Special Effects  
1960 Blue Heron Drive  
London, Ontario N6H 5L9

Direct: 519-659-7972  
Toll Free: 866-534-5557  
Fax: 519-659-7713

### Europe Office

Ultratec Special Effects GmbH  
Dieselstrasse 30-40  
60314  
Frankfurt am Main  
Germany

Direct: 49-69-87-000-1850  
Fax: 49-69-87-000-1899

### Canadian Shipping Address

(For All Canadian Repairs)  
Ultratec Special Effects  
1960 Blue Heron Drive  
London, Ontario N6H 5L9

### USA Shipping Address

(For All USA Repairs)  
Ultratec Special Effects  
640 Gadson Street  
Groveland, Florida 34736

Please remember to include the **RA Number on all items being shipped for repairs.**

To retrieve an RA Number visit [www.ultratecfx.com](http://www.ultratecfx.com) and click on the "Service" section. Then click on "Return Authorization Request" which is located on the left hand side of the page.

If you have any questions or require assistance please contact service at 519-951-3357/866-534-5557 or by email at [Service@Ultratecfx.com](mailto:Service@Ultratecfx.com).